

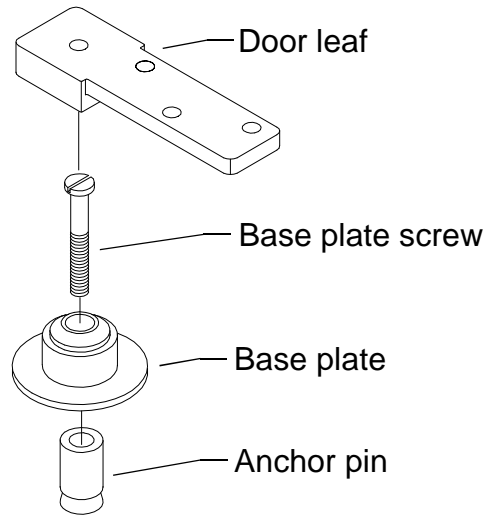

Installation Instructions

7253 Bottom Center Pivot



1. Prepare and mortise bottom of door and floor to receive pivot set. Determine pivot location using dimensions on reverse side. Depth of mortise in bottom of door will determine clearance. **Be sure to properly locate and mark pivot center point of the base plate.**
2. Locate, drill, and tap 1/4-20 mounting holes for metal door. Locate and drill pilot holes for #14 wood screws for wood door. Mount door leaf in bottom of door with 1/4-20 x 3/4" FHMS or #14 FHWS screws provided.
3. Drill 3/4" dia. x 1-3/4" deep hole in floor on center of pivot point for base plate mounting. **Pivot point of top pivot set must be plumb with bottom pivot point.** Insert anchor pin into hole and expand with tool. Insert base plate screw provided. Grout anchor pin in place. After grout has set, remove base plate screw.
4. Place base plate over anchor pin. Fasten to floor with base plate screw. Tighten securely.
5. If using a threshold, install threshold at this time.
6. Install top pivot set and hang door. Refer to top pivot set instructions.
7. If vertical height adjustment is necessary, use shims between door bottom and pivot leaf to increase clearance. To decrease clearance, mortise in door must be made deeper.



CAUTION

Improper pivot set installation can lead to personal injury or property damage. Follow all instructions carefully. For questions contact Technical Support at 1-888-371-7331.



NOTE

It is very important for installer to verify that center line of top pivot point lines up with center line of bottom pivot point before final installation.

Door Leaf

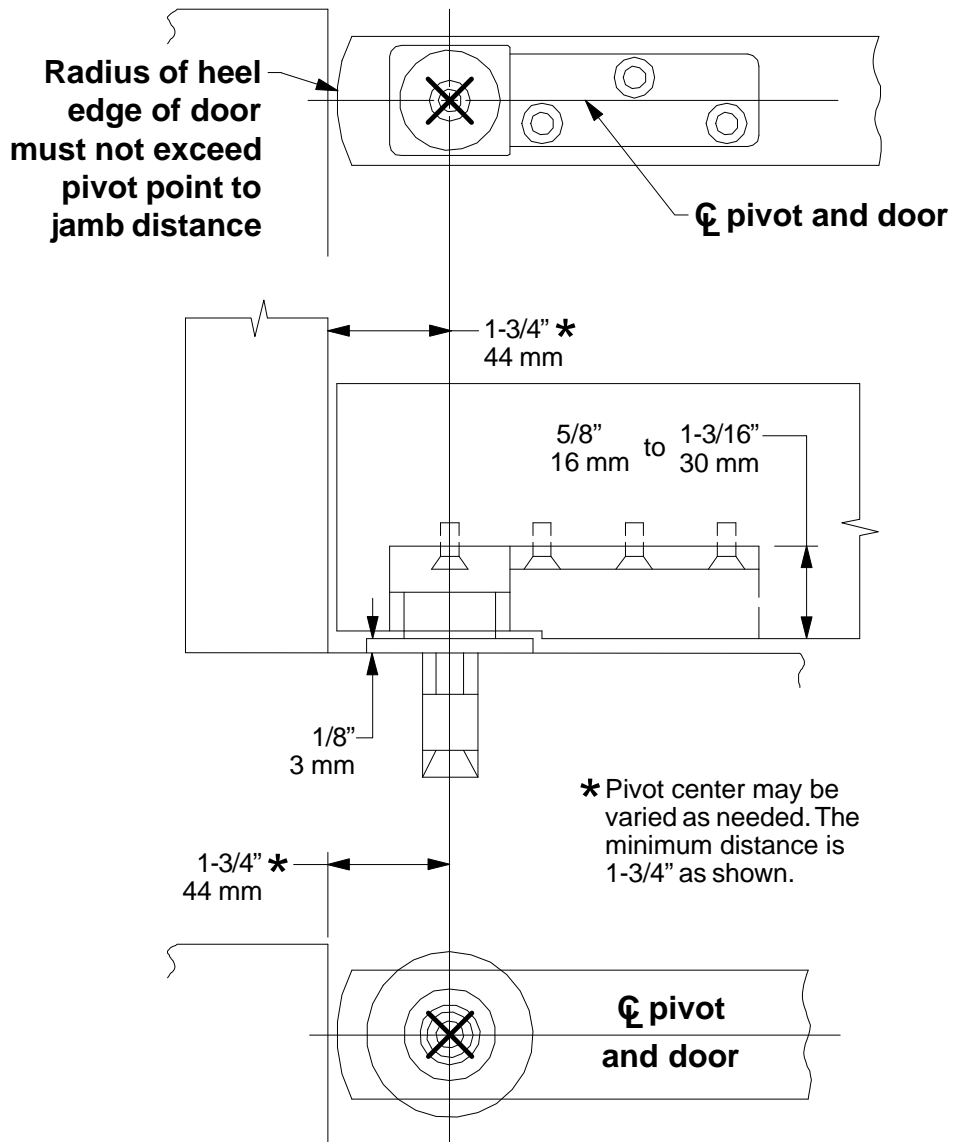

Pivot Base

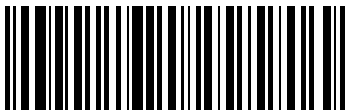

16002-00