

SINGLE DOOR INSTALLATION			
DEVICE	DIM "B"	DIM "C"	RECOMMENDED MIN STILE*
33A/35A RIM	19/32"	1 9/16"	2"
44 RIM EO,DT,NL,TP	1 11/16"	1 9/16"	3 3/8"
44 RIM K	1 9/16"	1 9/16"	3 3/8"
55 RIM	17/32"	1 9/16"	1 3/4"
22 RIM	1 9/16"	1 9/16"	3 13/16"
88 RIM EO,DT,NL,TP	1 11/16"	1 9/16"	3 3/8"
44 RIM K,L	1 9/16"	1 9/16"	3 3/8"
98/99 RIM	1 9/16"	1 9/16"	3 13/16"

LINE X-X CORRESPONDS TO LINE X-X ON DEVICE TEMPLATE

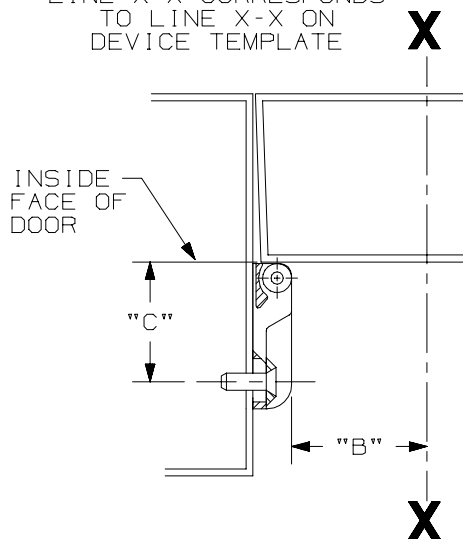

* CONSULT FACTORY FOR STILE WIDTHS LESS THAN MIN. RECOMMENDED TO ENSURE PROPER APPLICATION

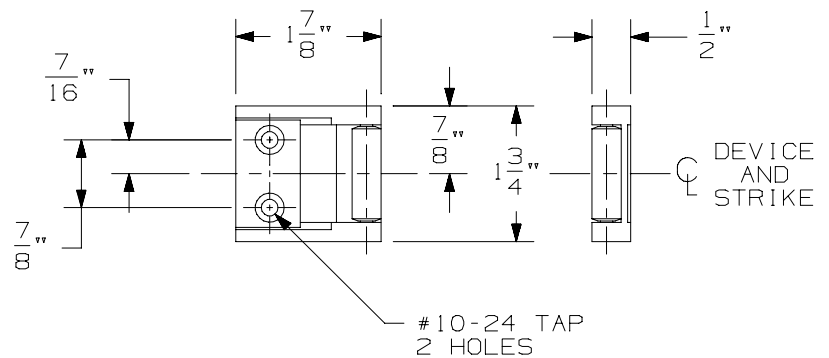

LHR APPLICATION SHOWN, RHR APPLICATION OPPOSITE

1439 ROLLER STRIKE

IR VON DUPRIN®

NOTE: SEE MASTER SHEET NO. 10001 FOR SUGGESTED REINFORCING.

TEMPLATE NUMBER: 30029_1

DATE: 02-06-04